

Data sheet

**linkIQ®/wM-Bus  
inputs(In-A, In-B)  
outputs(Out-C, Out-D), EU**

**MULTICAL® 403**  
**MULTICAL® 603**  
**MULTICAL® 803**

- Standardized Wireless M-Bus communication according to EN 13757-4
- Optional linkIQ® communication solution
- Configurable datagrams
- Radio with optimised battery and range
- Supports the highest security level (individually encrypted meters)
- Robust infrastructure providing reliable data delivery
- Provides predictable lifetime
- Plug-and-play installation
- Pulse in- or outputs available

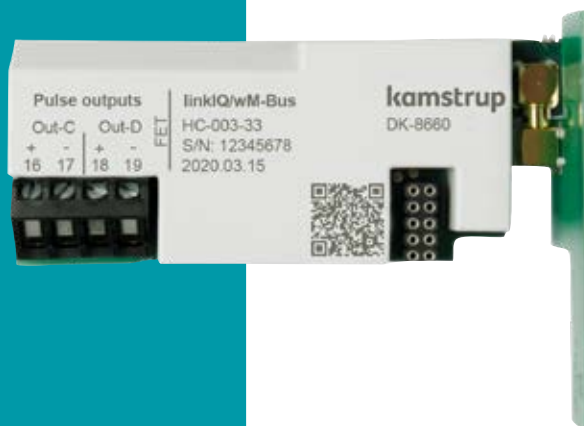

## General description

---

A remote reading solution from Kamstrup is designed to ensure a reliable delivery of data and at the same time a predictable battery lifetime of end devices.

A new flexible wireless communication module (linkIQ®/w-M-Bus module) for MULTICAL® 403/603/803 is developed to support the best possible remote reading system for our customers – regardless of the solution chosen (Walk-by/Drive-by/Fixed Network)

### The module

The linkIQ®/wM-Bus interface for MULTICAL® 403, 603 and 803 is a plug-in module for fast and reliable installation in the module area of the meter and is designed with “state-of-the art” radio technology while still maintaining a strong focus on a long battery lifetime.

It is possible to have the module configured with different predefined datagrams for, for example, Walk-by/Drive-by/Fixed Network applications from factory. It is also possible easily to change between available datagrams on site.

Besides support for the well-known Wireless M-Bus communication protocol, the module also supports the new linkIQ® communication protocol, and customer-specified datagrams can be tailor-made for specific applications for both protocols.

## Applications

---

### Wireless M-Bus

Wireless M-Bus is a standardized communication protocol, developed for remote reading of consumption meters, and the module fulfils the requirements of the latest M-Bus standard EN 13757-4 as well as the OMS Primary Communication. Furthermore, it works in a wide variety of applications which use the M-Bus protocol.

### linkIQ®

linkIQ® is a new communication technology for remote reading of meters in a fixed network, designed specifically for long range smart metering.

By default, the module is available in 4 different combinations:

- linkIQ® + wM-Bus C2
- wM-Bus C1 + wM-Bus C2
- wM-Bus T1 OMS + wM-Bus C2
- wM-Bus T1 BSI

Among the features are:

- Support of both 1- and 2-way communication
- Supports Walk-by, Drive-by and Fixed Network installations
- Configurable datagrams for various applications
- Prepared for both C-, T-, and linkIQ® mode communication solutions
- Large set of already configured datagrams available
- Remote meter configuration, e.g. for changing the data package content
- Remote firmware upload for extended functionality
- Long meter battery lifetime at high readout rates

With the 2-way communication functionality, both the meter and the communication modules become very flexible and make it very easy to:

- Change from Walk-by to a Fixed Network installation and vice versa
- Switch between C-mode, T-mode and linkIQ®
- Choose the datagram that fits the customer needs

All this without having to disturb the end customer in order to gain access to the meter.

Furthermore, the 2-way communication functionality allows adding future applications to both the communication module and the meter – thus making the installation future-proof.

## Cable connections

### Terminals

Max cable size 1.5 mm<sup>2</sup>

#### HC-003-32: linkIQ®/wM-Bus, inputs (In-A, In-B), EU

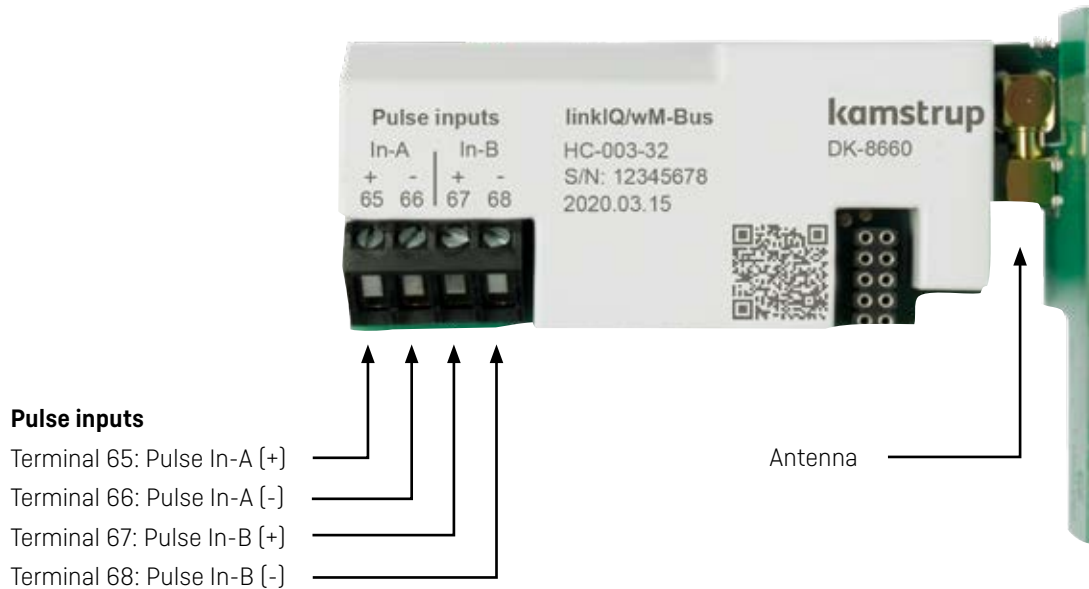

The module is equipped with two pulse inputs, In-A and In-B, to collect and accumulate pulses, e.g. from water and electricity meters.

The pulse inputs are physically placed on the module. However, the accumulation and logging of values are performed by the MULTICAL® calculator.

When installing a module with pulse inputs in slot 2 of MULTICAL® 603 and MULTICAL® 803, the pulse inputs will be registered in the meter as In-A2 and In-B2.

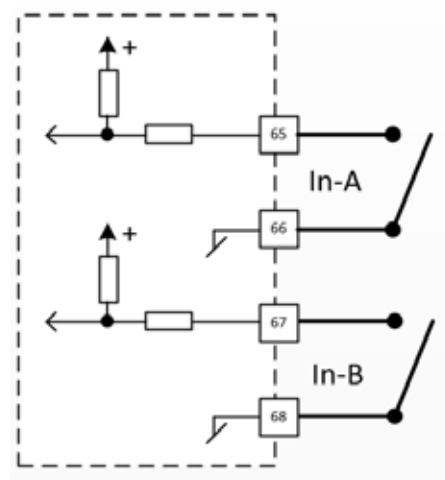

## Cable connections

### Terminals

Max cable size 1.5 mm<sup>2</sup>

### HC-003-33: linkIQ®/wM-Bus, outputs (Out-C, Out-D), EU

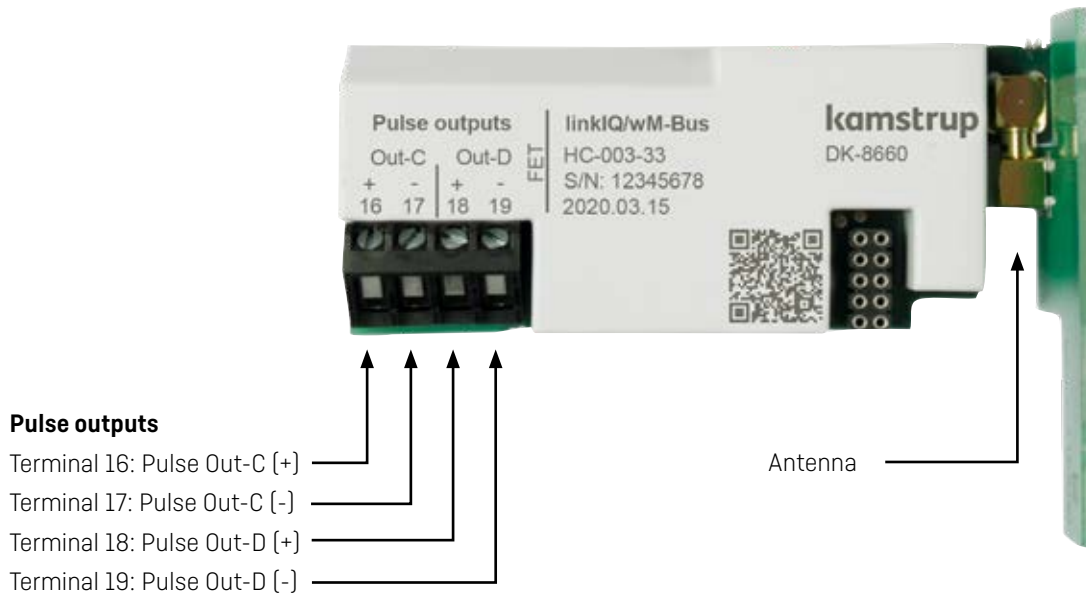

#### Pulse outputs

- Terminal 16: Pulse Out-C (+)
- Terminal 17: Pulse Out-C (-)
- Terminal 18: Pulse Out-D (+)
- Terminal 19: Pulse Out-D (-)

The module has two configurable pulse outputs, Out-C and Out-D, which are used for pulsing out selected registers from the MULTICAL® calculator.

The pulse outputs are physically placed on the module, but the pulses are generated by the MULTICAL® calculator.

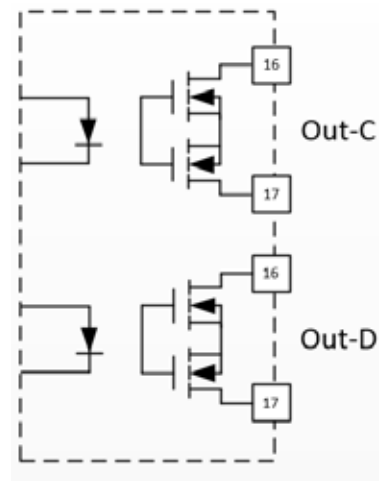

## Antenna



This radio-based module must have either an internal or external antenna connected. When mounting an external antenna, please ensure that the antenna cable is arranged in such a manner that damage of the cable is prevented when the meter is assembled.

## Datagrams

There are different datagrams available.

### Wireless M-Bus datagrams

The first Wireless M-Bus datagrams were made in 2010 and today, more than 50 different datagrams are available for Walk-by/Drive-by and Fixed Network solutions.

Below is an example of a datagram. For information regarding other datagrams, please refer to the Logger Profiles and Datagram description (doc. 55122699).

#### 32-10-102: C1, Drive-by, alternative registers

		Interval: 16 s	Walk-by/Drive-by	<b>MULTICAL® 403</b>
<b>Wireless M-Bus datagram</b>	YY = 10	25 mW	C1, 868 MHz	<b>MULTICAL® 603</b>
	ZZZ = 102		Frame format B	<b>MULTICAL® 803</b>
<b>Estimated battery lifetime</b>		1 x D-Cell	15 years	
		2 x A-Cell	7 years	

No.	Register ID	Register name	Register origin	St. no.	Data type	Notes	H	C	H/C	V
1	60	Heat energy E1					X		X	
2	63	Cooling energy E3						X		
3	63	Cooling energy E3				HCC			X	
4	97	Energy E8					X	X	X	
5	110	Energy E9					X	X	X	
6	68	Volume V1					X	X	X	X
7	84	Pulse input A1					X	X	X	X
8	85	Pulse input B1					X	X	X	X
9	74	Flow V1 actual					X	X	X	X
10	86	t1 actual [2 decimals]			Int2		X	X	X	
11	87	t2 actual [2 decimals]			Int2		X	X	X	
12	128	Power max year					X	X	X	
13	64	Tariff TA2					X	X	X	
14	65	Tariff TA3					X	X	X	
15	369	Info bits					X	X	X	X
16	348	Date			Int2		X	X	X	X
17	60	Heat energy E1	Month log	1			X		X	
18	63	Cooling energy E3	Month log	1				X		
19	63	Cooling energy E3	Month log	1		HCC			X	
20	68	Volume V1	Month log	1			X	X	X	X
21	84	Pulse input A1	Month log	1			X	X	X	X
22	85	Pulse input B1	Month log	1			X	X	X	X
23	348	Date	Month log	1	Int2		X	X	X	X

## Datagrams

### linkIQ® datagrams

linkIQ® is a new communication technology for remote reading of meters in a fixed network, designed specifically for long range smart metering.

With this technology, you can get data at hourly basis, daily basis, monthly basis and annual basis. All our linkIQ® datagrams are designed to provide 16 years of battery life with a D-cell battery and 8 years with 2xA cells. In the datagram description, you see the specified capacity, which means how many meters with this datagram can be handled by one READy Concentrator 1M. It is also stated which RR code we recommend for a meter with a module using the specific datagram.

Below is shown the standard datagram. For all our datagrams see the linkIQ® Datagram description document no 55123019.

#### 32-50-501: linkIQ® Standard datagram

linkIQ® datagram	RR = 52	Interval: 8-22min	MULTICAL® 403
	YY = 50	25 mW	MULTICAL® 603
	ZZZ = 501	Capacity = 10.000	MULTICAL® 803

No.	Register ID	Register name	Register origin	H	C	H/C	V
1	369	InfoBits	ActualMeterData	X	X	X	X
2	60	E1	HourLog	X		X	
3	63	E3	HourLog		X	X	
4	97	E8	HourLog	X	X	X	
5	110	E9	HourLog	X	X	X	
6	68	Volume V1	HourLog	X	X	X	X
7	1004	Operating hours	DayLog	X	X	X	X
8	175	Error hour counter	DayLog	X	X	X	X
9	369	Infobits	DayLog	X	X	X	X
10	139	Flow V1 max month	MonthLog	X	X	X	X
11	138	Flow V1 max month date	MonthLog	X	X	X	X
12	143	Power max month	MonthLog	X	X	X	
13	142	Power max month date	MonthLog	X	X	X	

## Technical data

### Physical

For installation in MULTICAL® 403, MULTICAL® 603 and MULTICAL® 803

### Mechanical data

Dimensions (L x W x D) 90 x 35 x 14 mm  
Weight < 45 g

### MULTICAL® supply

 Battery or AC supply

Radio communication	Wireless M-Bus, mode C + T	linkIQ®
Transmit frequency/-cies	868.950 MHz	868 - 870 MHz
Receive frequency (C2)	869.525 MHz	869.525 MHz
Communication solution	Wireless M-Bus, C- and T-mode, EN 13757-4:2013	linkIQ®
Transmission interval	16/96/900 seconds	8 - 22 minutes - meter type dependent
Transmission power	25 mW	25 mW
Range	Internal antenna <300 m External antenna <600 m	Up to 5 km

### Pulse inputs

Input type Contact input  
Open voltage 3.6 V  
Current ≤ 5 µA  
Max cable length 10 m

### Pulse outputs

Output type Opto Fet  
External voltage 5...45 VAC/VDC  
Current 1...50 mA  
R<sub>ON</sub> ≤ 40 W  
Max cable length 25 m

### Environment

Operational temperature 5 °C - 55 °C  
Humidity 25 - 85 % RH non-condensing

### Markings/approvals

CE, MID, RED together with the type approval of MULTICAL® 403, MULTICAL® 603 and MULTICAL® 803

### Compatibility

EN 13757 M-Bus standard

### Programming

Configuration Via the multipole connector on the module using METERTOOL HCW  
Firmware C2 via READY Converter

### Battery lifetime

Expected Up to 16 years (D-cell)  
Depends on selected module configuration

linkIQ®/wM-Bus, inputs (In-A, In-B)  
linkIQ®/wM-Bus, outputs (Out-C, Out-D), EU

MULTICAL® 403  
MULTICAL® 603  
MULTICAL® 803

## Ordering

---

<b>Description</b>	<b>Order No.</b>
linkIQ®/wM-Bus, inputs (In-A, In-B), EU	HC-003-32
linkIQ®/wM-Bus, outputs (Out-C, Out-D), EU	HC-003-33
USB configuration cable for H/C-modules	6699 035
Infrared optical read-out head w/USB A plug	6699 099
Internal antenna 868 MHz	6699 482
External antenna (mini-Triangle)	6699 448
METERTOOL HCW	<a href="http://www.kamstrup.com">www.kamstrup.com</a>
USB Meter Reader	<a href="http://www.kamstrup.com">www.kamstrup.com</a>
READY	<a href="http://www.kamstrup.com">www.kamstrup.com</a>

---

### **Kamstrup A/S**

Industrivej 28, Stilling  
DK-8660 Skanderborg  
T: +45 89 93 10 00  
F: +45 89 93 10 01  
[info@kamstrup.com](mailto:info@kamstrup.com)  
[kamstrup.com](http://kamstrup.com)